

29/01/13 (rev 2)

**Vista HP**



**Manual**

 **APCO Aviation**  
*Setting Future Standards*

Factory: 7, Chalamish Street - Industrial Park - Caesarea 38900 ISRAEL [www.apcoaviation.com](http://www.apcoaviation.com)  
Tel: +972 4 6273727 Fax +972 4 6273728



**CONTENTS:**

1	VISTA HP TECHNICAL DATA	4
2	VISTA HP CERTIFICATION DATA	4
3	DISCLAIMER OF LIABILITY	5
4	CONSTRUCTION	5
5	MATERIALS	6
6	FLEXON® Batten system:	6
7	TRIMMING	7
8	HARNESS	7
9	SPEED SYSTEM	7
9.1	ASSEMBLY & ADJUSTMENT	7
9.2	OPTION 1	7
9.3	OPTION 2	8
10	EMERGENCY PARACHUTE ATTACHMENT	9
11	RISERS	10
12	TRIMMERS	12
13	HIT VALVES (High speed In-Take)	13
14	SRS – Stall Recovery System	14
15	HYBRID REFLEX PROFILE	16
16	INSPECTION	17
16.1	GENERAL	17
16.2	BRAKE SETTING	17
16.3	FIRST CHECK AND PREFLIGHT INSPECTION	17
16.4	REGULAR INSPECTION CHECKS	18
16.5	LINE MAINTENANCE	18
17	FREE FLYING	19
17.1	TAKE OFF	19
17.1.1	LAYOUT	19
17.1.2	ALPINE LAUNCH OR FORWARD LAUNCH	19
17.1.3	STRONG WIND AND REVERSE LAUNCH	19
17.1.4	TOW OR WINCH LAUNCHING	20
17.2	FLIGHT TECHNIQUES	20
17.2.1	FLYING SPEED	20
17.2.2	THERMAL FLYING	21
17.2.3	ASYMMETRIC COLLAPSE	21
17.2.4	CRAVAT	21
17.2.5	FRONT STALL OR SYMMETRIC COLLAPSE	21
17.2.6	B-STALL	21
17.2.7	BIG EARS	22
17.2.8	DEEP STALL OR PARACHUTAL STALL	22
17.2.9	SPIRAL DIVES	23
17.2.10	STRONG TURBULENCE	23
17.2.11	STEERING NOT FUNCTIONING	23
17.2.12	LANDING	24
17.2.13	TREE LANDING	24
17.2.14	WATER LANDING	24
17.2.15	LANDING IN TURBULENCE	24
18	POWERED FLYING	25
18.1	FIRST FLIGHTS	25
18.2	TAKE-OFF	25



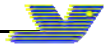

18.2.1	FORWARD LAUNCH	25
18.2.2	REVERSE LAUNCH (In strong wind)	27
18.2.3	CLIMBING	28
18.3	LEVEL FLIGHT	29
18.4	TRIMMERS AND SPEED-SYSTEM SETTINGS	29
18.5	LANDING	30
18.5.1	POWER OFF LANDING	30
18.5.2	POWERED LANDING	30
19	PACKING	32
20	MAINTENANCE & CLEANING	32
20.1	BUTT HOLES (Velcro closure on trailing edge tip)	32
21	STORAGE	32
22	DAMAGE	33
23	GENERAL ADVICE	33
24	VISTA HP SMALL SKETCHES	34
25	VISTA HP MEDIUM SKETCHES	35
26	VISTA HP SMALL CERTIFICATION	36
27	VISTA HP MEDIUM CERTIFICATION	39

**WARNING**

This is not a training manual. It is extremely dangerous to yourself and others to attempt to fly this or any paraglider without first completing a flying course given by a qualified instructor.

Apco Aviation's gliders are carefully manufactured and inspected by the factory. Please use the glider only as described in this manual. Do not make any changes to the glider.

**AS WITH ANY SPORT - WITHOUT TAKING THE APPROPRIATE PRECAUTIONS, PARAGLIDING CAN BE DANGEROUS.**





# 1 VISTA HP TECHNICAL DATA

<b>Size</b>	<b>Small</b>	<b>Medium</b>	
<b>Cells</b>	46	48	
<b>Area m<sup>2</sup></b>	23.3	24.9	
<b>Area (projected) m<sup>2</sup></b>	20.4	22.0	
<b>Span (incl. Stabiliser) m</b>	11.02	11.63	
<b>Span (projected) m</b>	9.02	9.64	
<b>Aspect Ratio</b>	5.2	5.4	
<b>Aspect Ratio (projected)</b>	4.0	4.2	
<b>Pilot Weight, Kg (all up) free flight</b>	70-100	85-120	
<b>Pilot Weight (all up + paramotor) Kg</b>	75-140	100-165	
<b>Weight of Canopy Kg</b>	5.7	5.9	
<b>Root Cord m</b>	2.59	2.59	
<b>Tip Cord m</b>	0.51	0.51	
<b>Length of Lines on B m</b>	6.9	7.4	
<b>Total length of line used m</b>	311	339	
<b>LINES</b>			
	<b>Material</b>	<b>Diameter</b>	<b>Strength</b>
<b>Top</b>	Dyneema	1.0mm	90kg
<b>Mid;st</b>	Super Aramid	1.2mm	120kg
<b>Bottom A3;A5;B3;B5</b>	Super Aramid	1.8mm	230kg
<b>Bottom A1;B1</b>	Super Aramid	1.9mm	320kg
<b>Bottom C ; D</b>	Super Aramid	1.5mm	150kg
<b>Brake Cascades; st top</b>	Dyneema	1.1mm	95kg
<b>Steering Line</b>	Polyester	2.0mm	85kg
<b>FABRIC</b>			
<b>Sail Cloth</b>	"Zero Porosity" Ripstop Nylon		
<b>Warranty</b>	3 Years / 250 hours		

<b>GLIDER PERFORMANCE DATA</b>	
V-min.	22km/h
V-trim	39/40 km/h
V-trim off	46-48 km/h
V-max.	62+ km/h
Min Sink ( at optimum wing loading)	less than 1.2 m/s

# 2 VISTA HP CERTIFICATION DATA

<b>GLIDER CERTIFICATION DATA</b>	
VISTA HP SMALL	EN – B Certification Flight test
VISTA HP MEDIUM	EN - C Certification Flight test



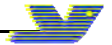

### 3 DISCLAIMER OF LIABILITY

Taking into consideration the inherent risk in paragliding, it must be expressly understood that the manufacturer and seller do not assume any responsibility for accidents, losses and direct or indirect damage following the use or misuse of this product.

APCO Aviation Ltd. is engaged in the manufacture and sale of hang gliding, paragliding, motorized Para/hang gliding and emergency parachute equipment.

This equipment should be used under proper conditions and after proper instruction from a qualified instructor. APCO Aviation Ltd. has no control over the use of this equipment and a person using this equipment assumes all risks of damage or injury.

APCO Aviation Ltd. disclaims any liability or responsibility for injuries or damages resulting from the use of this equipment.

The glider is designed to perform in the frame of the required class as certified.

### 4 CONSTRUCTION

The glider is constructed with a top and bottom surface, connected by ribs.

One top and bottom panel, together with the connecting ribs is called a cell.

Each cell has an opening on the front lower part. The cells fill with air forcing the panels to take the shape dictated by the airfoil (rib) section.

On either side the wing ends in a stabilizer or wing tip, which provides straight-line (Yaw) stability and produces some outward force to keep the span-wise tension.

The front part of the ribs use APCO's FLEXON batten system to keep the leading edge shaped at high speeds and in turbulent air. They also improve the performance and the launch characteristics of the glider.

The line hook-up points are made of Dyneema and imbedded in the bottom surface of the wing for minimal drag and maximum performance.





## 5 MATERIALS

The glider is made from tear resistant Ripstop Nylon cloth, which is P.U. coated to zero porosity and then siliconized to give the fabric high resistance to the elements. Different cloth is used for the top, bottom and ribs due to their different functions.

The lines are made of superaramid covered with a polyester sheath for protection against UV, wear and abrasion.

The bottom section of the brake lines are made of polyester because of its better mechanical properties.

The carabiners that attach the lines to the risers are made of stainless steel.

## 6 FLEXON® Batten system:

New generation FLEXON ® batten system incorporated (see below) in the leading edge of the ribs, insuring perfect profile shape (instead of traditional Mylar reinforcement). FLEXON ® battens reduce the weight of the glider by an additional 500gr. and unlike Mylar reinforcement will guarantee no deterioration in performance or launch.

Additional advantage of FLEXON batten is that it is practically indestructible, safeguarding the performance and launch over the lifespan of the glider.

### How it Works:

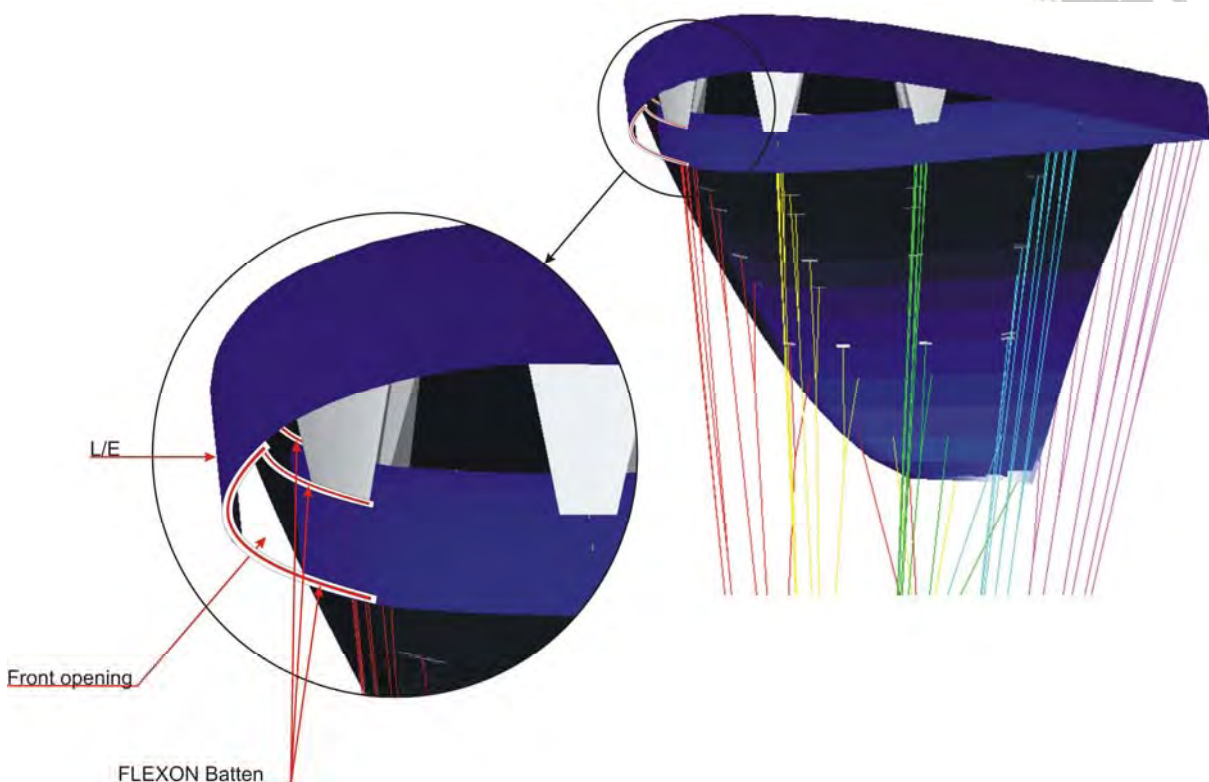



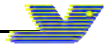

## 7 TRIMMING

All Apco gliders are trimmed for optimum performance combined with unsurpassed safety. It is very important not to re-trim or tamper with any of the lines or risers as this may alter the performance and safety. Trimming of the brake line should be done in accordance with this manual and carefully checked before flying.

## 8 HARNESS

All of Apco's gliders are developed with the use of ABS (Automatic Bracing System) type harnesses without cross bracing. We recommend the use of an ABS harness with all our gliders. All certified harnesses can be used with our gliders. For best safety and performance we recommend an Apco harness equipped with a Mayday emergency parachute.

### **CAUTION:**

#### **WE RECOMMEND NOT TO USE CROSS BRACING STRAPS.**

APCO GLIDERS ARE DEVELOPED AND TESTED WITHOUT THE USE OF CROSS BRACING. USING AN ABS HARNESS WITH CHEST STRAP SET AT THE SPECIFIED WIDTH (CHECK THE CERTIFICATION STICKER ON YOUR GLIDER) WILL RESULT IN THE HIGHEST PASSIVE SAFETY ON YOUR GLIDER.

## 9 SPEED SYSTEM

### 9.1 ASSEMBLY & ADJUSTMENT

Apco gliders are supplied with a speed system as illustrated in option I. The pilot can change the speed system to the traditional "Apco" speed system to use the full accelerator range depending on the pulley arrangement on the harness being used (Option II)

### 9.2 OPTION 1

First attach the harness to the glider. Remove the Chain Link from the end of the accelerator line attached to the speed bar, then thread it through the elasticized ring on the harness, then through harness pulley and then re-attach it to the Chain link with a larks-head knot. Hook the Chain link onto the Chain Link on the riser of the corresponding side. Sit in the harness and have someone hold the riser up in a flying position for you. Adjust the speed bar line by pulling the end through the speed bar tube and moving the knot. The Bar should be about 10 cm (or closer if you have a second step) away from the front of the harness seat. This allows you to easily reach the bar with your foot, and will allow you to use the full range of the speed bar if you extend your legs fully. Do not adjust the speed system too short, as this will cause it to be activated permanently while flying, and could be dangerous. It is possible to fit a second step to the system, if one has trouble using the full range of the system (supplied separately).





## OPTION I

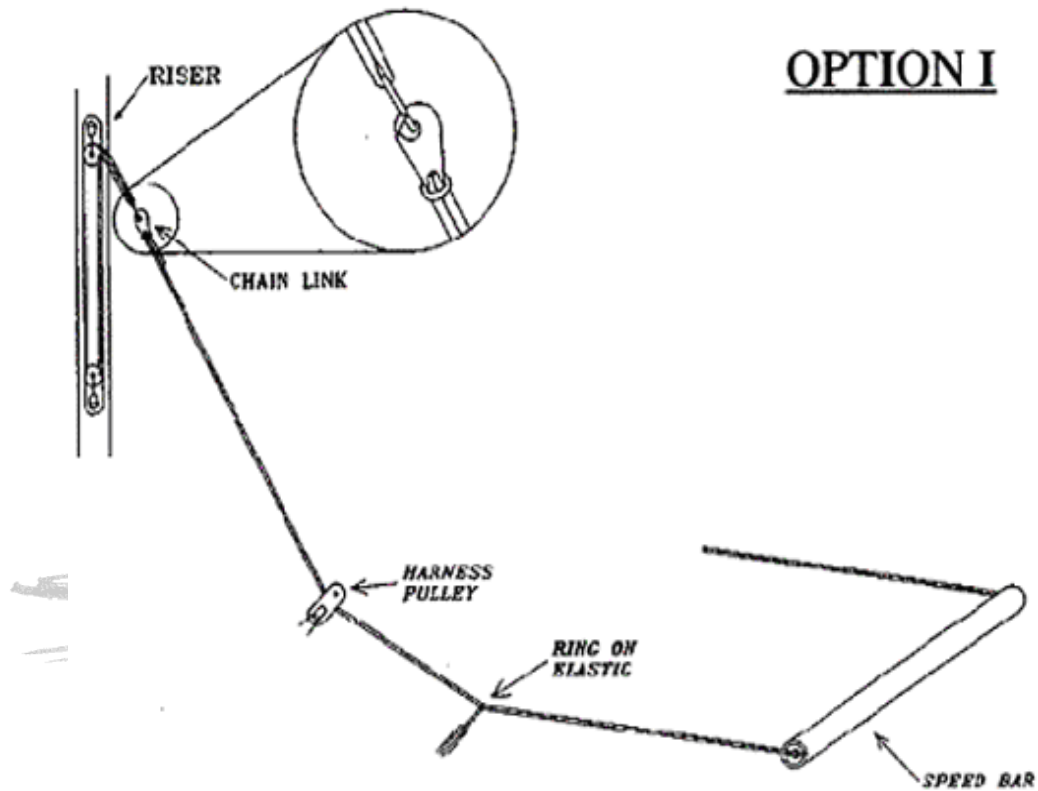

Figure 9-1

### 9.3 OPTION 2

First attach the harness to the glider, then thread the accelerator line from the top pulley on the riser, through the pulleys (and the elasticized ring if present) on your harness and then attach it to the supplied speed bar. To adjust the length and activation point of the speed system, sit in the harness and ask someone to hold the riser up in a flying position. By pulling out the end of the line protruding above the upper pulley on the riser and by moving the knot you can adjust the speed system. The Bar should be about 10 cm ( or closer if you have a second step) away from the front of the harness seat. This allows you to use the full range of the speed bar if you extend your legs fully. Do not adjust the speed system too short as this will cause the speed system to be activated permanently while flying and could be dangerous. It is possible to fit a second step to the system if the pilot has trouble using the full range of the speed system (second step is supplied separately).





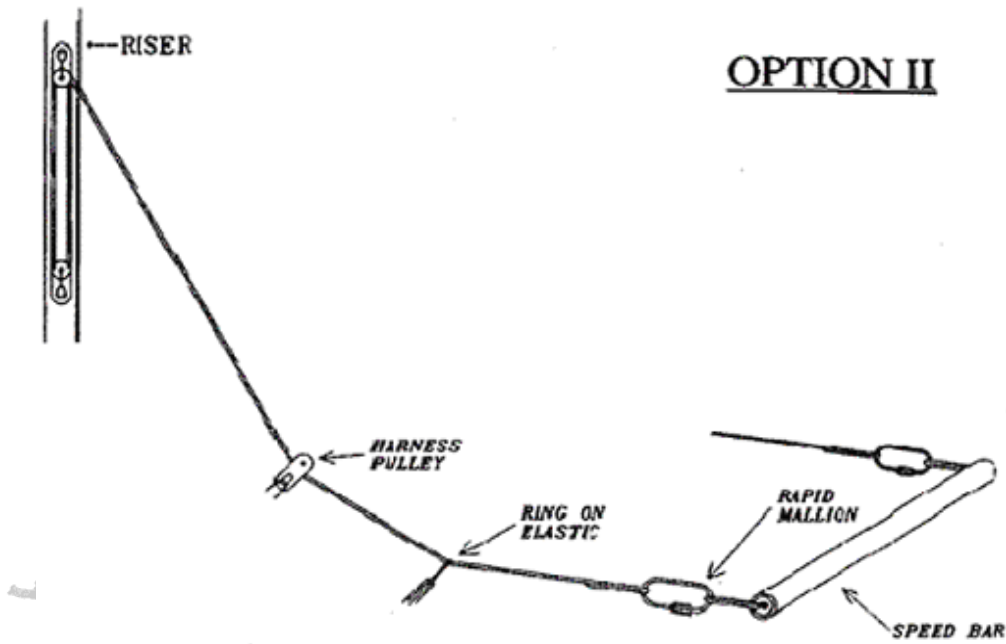

Figure 9-2

**WARNING:**

The use of the speed system in turbulent conditions or close to the ground is dangerous. While flying with the accelerator, the glider has a reduced angle of attack and is therefore more susceptible to turbulence and may collapse or partially deflate. Gliders react faster when accelerated and may turn more. The accelerator should immediately be released in this case.

## 10 EMERGENCY PARACHUTE ATTACHMENT

It is recommended to use a certified rescue parachute when flying. Attaching the rescue parachute should be done in accordance with the recommendation of the harness and reserve parachute manufacturer.





## 11 RISERS

The VISTA HP is supplied with risers featuring a split A riser. The 1st A-riser attaches to the central two A lines (A1 & A3). The second A-riser is attached to the outermost A line (A5). This is to facilitate Big ears or Tip tucks. At no time should the pilot change the risers or use risers not intended for this specific glider as this will affect the performance and safety of the glider.

The riser is equipped with both an accelerator and trimmers with two hook-in points to accommodate different type of paramotors (low or high attachment point).

The lower hook-in point should be used with a paramotor harness with a low harness hook-in point or a regular paragliding harnesses.

The higher hook-in point should be used when flying a paramotor harness with shoulder-height hook-in connections.

The brake line is guided through upper pulley for free-flying paragliding and adjusted as per Section 16.2(see Figure 16-1).

For paramotor flying you can use the same brake line setting for a low hook-in paramotor harness, same as a paragliding harness, or guide the brake line through the lower brake guide pulley when using a paramotor with high attachment points.



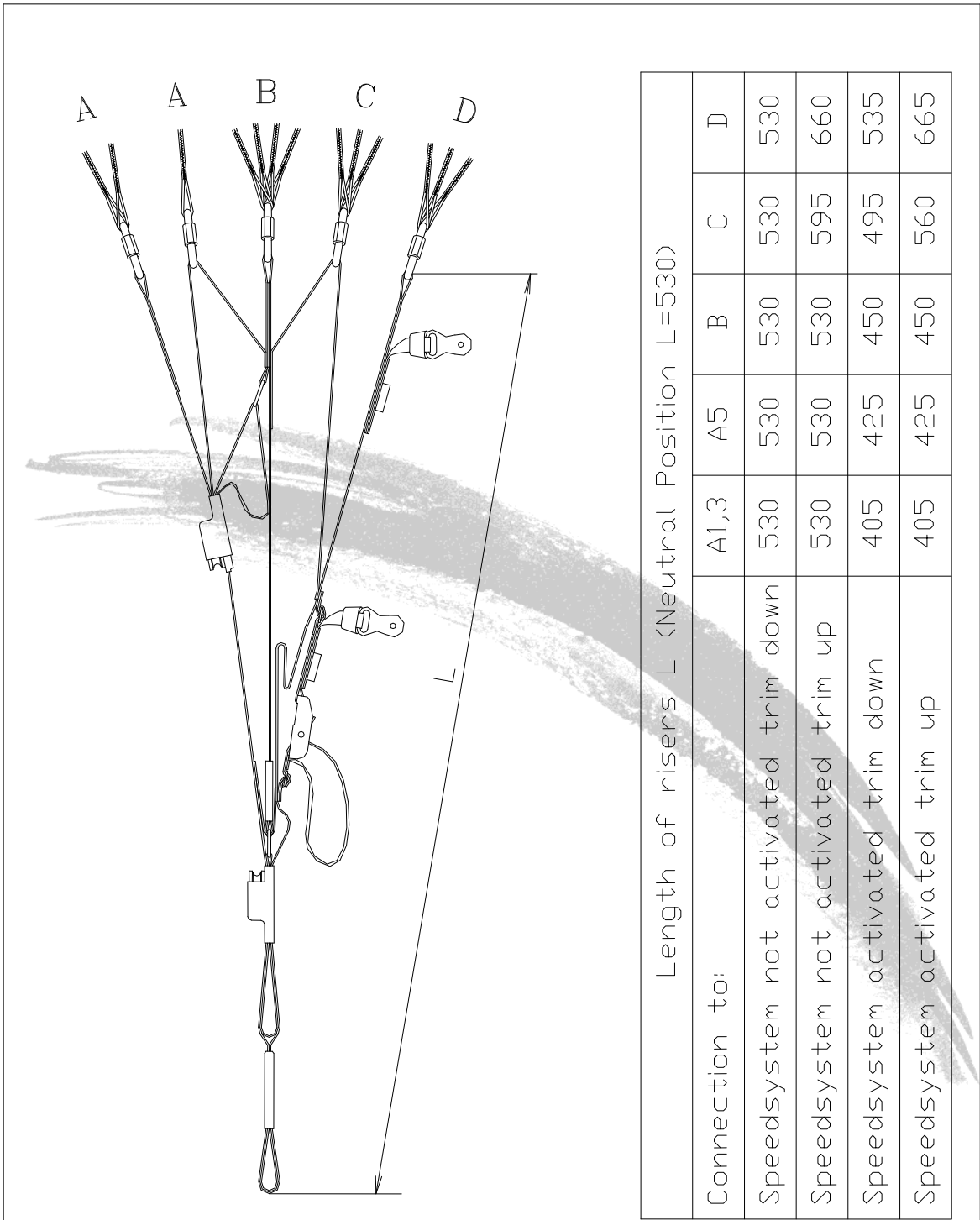

Length of risers L (Neutral Position L=530)

Connection to:	A1,3	A5	B	C	D
Speedsystem not activated trim down	530	530	530	530	530
Speedsystem not activated trim up	530	530	530	595	660
Speedsystem activated trim down	405	425	450	495	535
Speedsystem activated trim up	405	425	450	560	665

\* All measurements are in mm

Drawn by Adam Wechsler	Part N 70030	Toll	Quantity per glider
Date 04.03.09	Name		Drawing N
Scale	RISER		
Approved Anatoly Cohn			
APCO Aviation LTD. 		Product	Vista HP





## 12 TRIMMERS

The Vista HP risers are equipped with replaceable trimmers for accelerated flight. The neutral setting is when the trimmers are fully closed and A/B/C/D riser lengths are equal. We recommend performing landing and take-off with the trimmers closed. Trimmers should be used when higher speed is required and you wish to accelerate the glider.

### Replaceable trimmer system

1. Undo the safety stitch of kamet or trim webbing, depending on what requires replacement.

2. Take out the kamet or trim webbing requiring replacement, by removing it from the slider buckle.

3. Replace trim webbing or kamet with new by guiding it back through the slider buckle, verify the trim range is unchanged, on trim speed all the riser branches are at equal height. When kamet fully released it should not retain any load (all the load is on the fully released D branch of the riser).

4. Restitch the safety stitch to lock the configuration of the trim in place.



## 13 HIT VALVES (High speed In-Take)

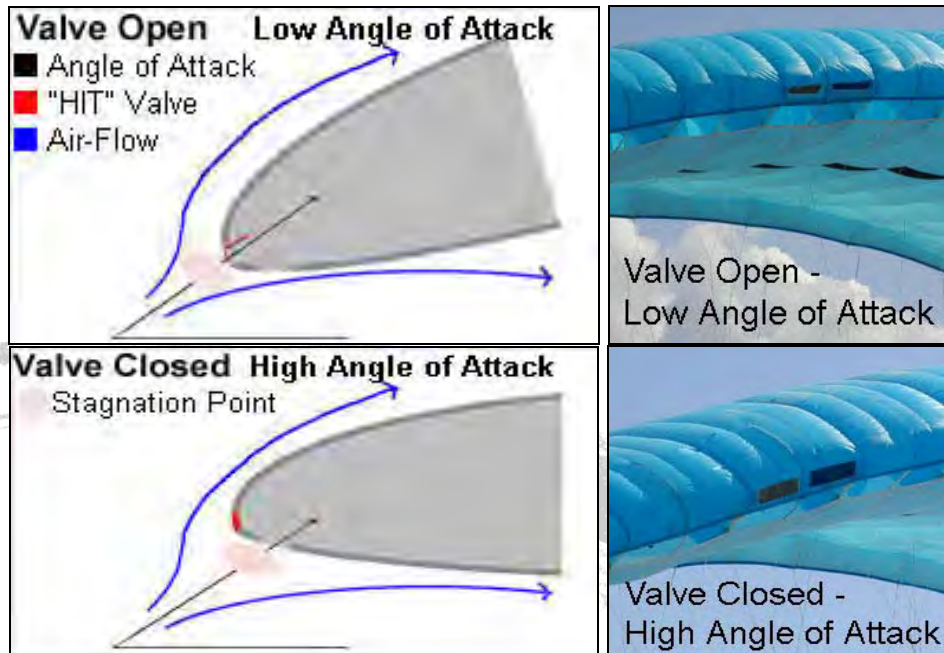

The Vista HP is equipped with an Active HIT Valve system (patent pending) to improve the overall performance and safety of the wing especially during accelerated flight.

The valve system allows maximum inflow of air when the glider acquires a lower angle of attack while accelerated. HIT valves open and close in flight to increase the internal pressure of the glider.

For the valves to work properly it is important to keep them wrinkle free especially in sub zero temperatures. Make sure the valves are lying flat and are in the closed position when you fold the glider. Before launch the pilot should check all the valves and verify that they are flat and cover the entire area of the mesh opening. Creased and wrinkled valves will not adversely affect the safety of the wing.





## 14 SRS – Stall Recovery System

The **Vista HP** features a new, innovative, riser design allowing to slow down the glider to minimum speed without risking getting caught in deep stall ( parachutal ). The **SRS** (patent pending) takes advantage of simple yet proven aeronautical and physical principles.

When flying, most of the load is applied to the front third of the wing. This means that the A lines bear significantly more load than the C+D lines together. However, when the glider is in deep stall ( parachutal ), the load is distributed almost evenly along the wing chord. Thus, in parachutal, the load on the C+D lines is considerably higher than on the A lines. Using this principle, we designed a self-compensating angle of attack (AofA) system based on a sliding riser concept.

The C+D risers join the A risers and slide in opposite direction. In flight, the A riser is taut and pulls the C+D to trim position. When forced into parachutal, The C+D risers elevate and pull down the A riser, accelerating the glider out of parachutal. Once recovered, the risers automatically resume trim position.

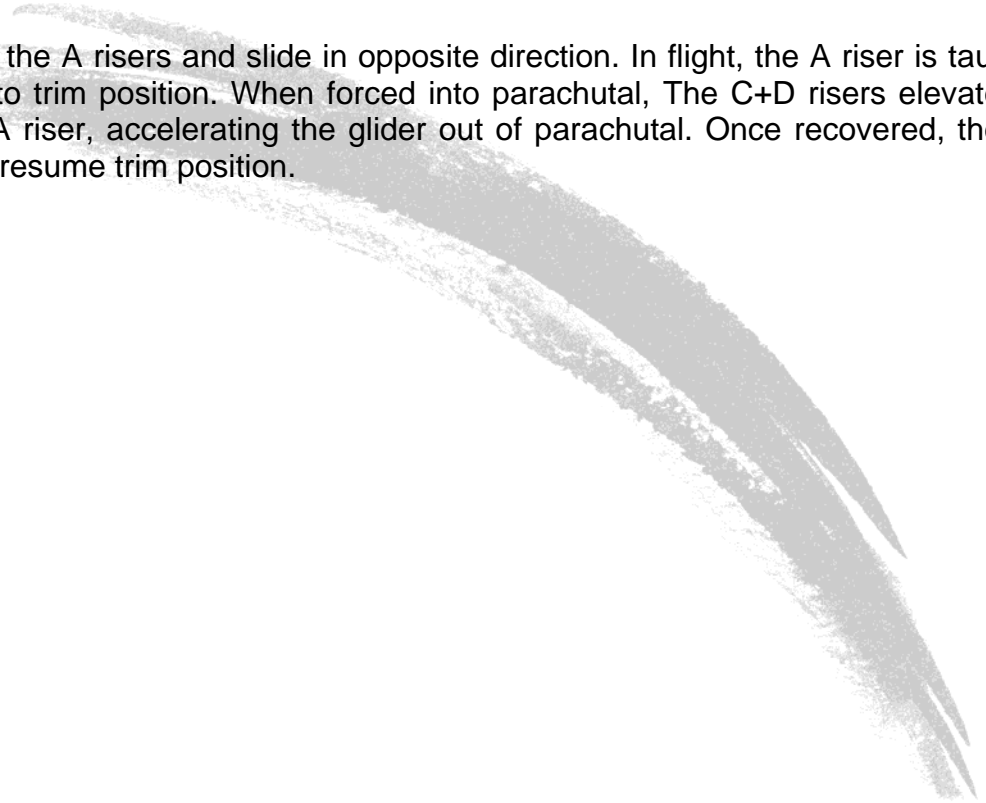





# APCO SRS - Automatic Stall Recovery System

1

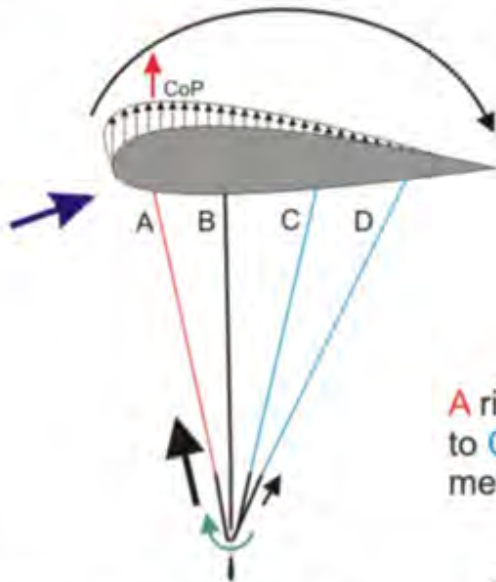

Load distribution in flight

2

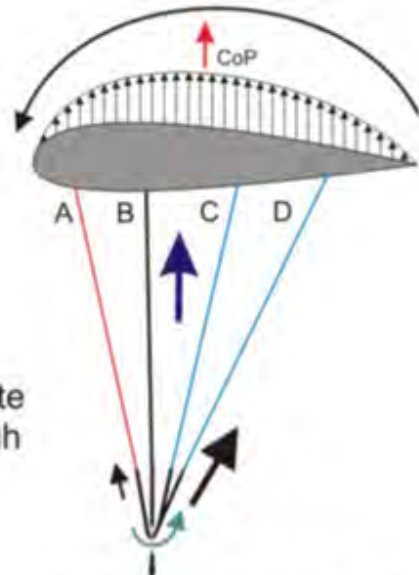

Load distribution in deep stall

A riser slides opposite to C&D risers through metal loop.



3

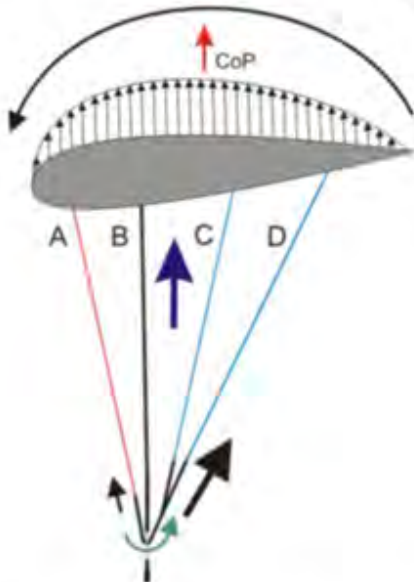

Automatic compensation of SRS

4

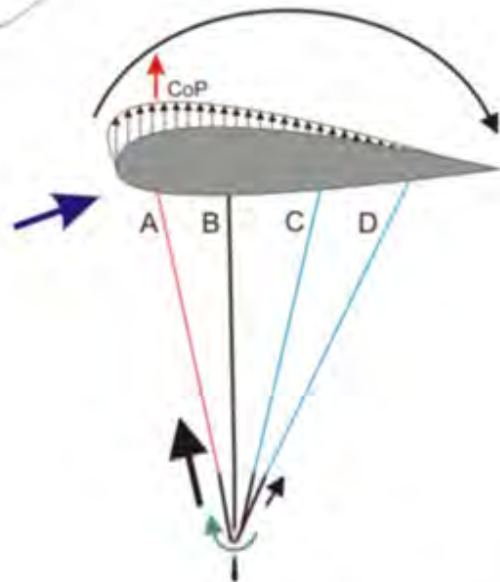

Load distribution in flight





## 15 HYBRID REFLEX PROFILE

One of the main advantages of VISTA HP is that it has been designed with hybrid reflex profile concept built-in. It combines the advantages of classic paragliding wing with reflex profile technology at high end of speed range.

Hybrid Reflex profile principles

Classic paragliding profile is converted into the full reflex profile by special line and riser arrangement.

At trim speed it is a typical paragliding profile with all parameters in line with good solid classic paraglider, having good launch, handling and stability. Once accelerated it is transformed into full reflex profile with all the virtues as such. The trim tabs released completely unload the C and D lines, allowing for the profile's rear part to bend up into the "S" shape – so called – reflex profile

The profile in reflex configuration does not create any lift at the rear part, effectively reducing the wing area and extending the aspect ratio. (Wing span unchanged / area reduced)

This phenomenon leads to higher wing loading, followed by sensation of greater stability and rigidity of the wing. Also the manageable top speed grows.

(Centre of Pressure moves forward adding extra stability and preventing any collapse. Internal pressure and rigidity of wing is improved at top end of the speed range) - see drawings below for a more graphic explanation.

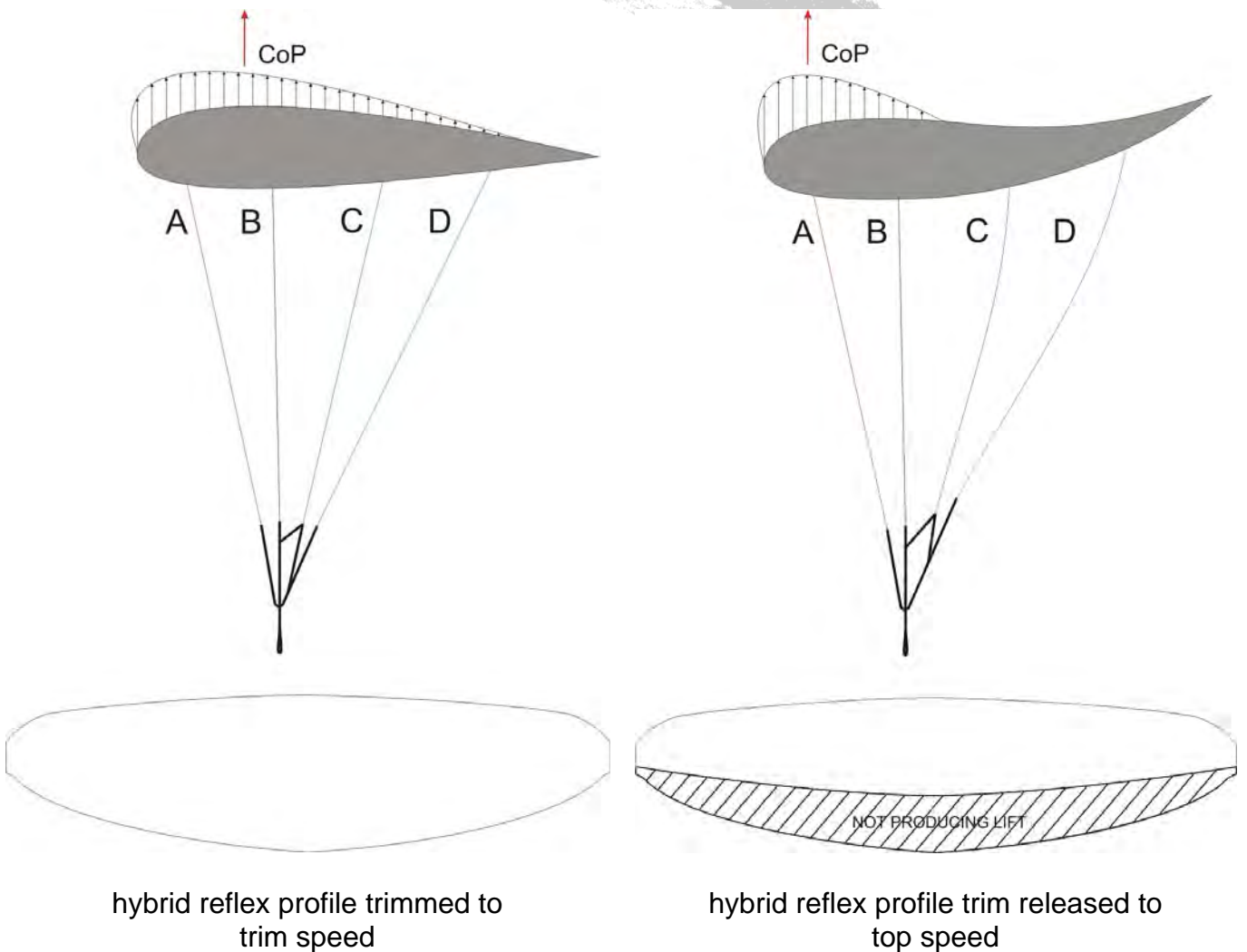



## 16 INSPECTION

### 16.1 GENERAL

Pilots, please insure that your glider has been test flown and fully checked by your dealer before taking it into your possession.

Verify that the dealer checked and confirms that the glider is airworthy.

### 16.2 BRAKE SETTING

Before the first flight the pilot/ dealer has to inflate the glider, check and adjust the brake line length to his or her preference. It is important that the brakes are not set too short. If the glider is above your head the brakes should not be pulling the trailing edge down as this means that the brakes are too short. A good setting is to have about 10 cm of slack in the brake from the brake guide on the riser to the activation point of the brakes (See Diagram 16-1 below). If the pilot changes the type of spreader bar, please check the brakes again to ensure that the brakes are not too short.

Since there are several hook-up points for a paramotor, the Vista HP comes with longer brake lines than necessary. The risers also have two anchor loops for the brake line guide-pulley so that the pilot can arrange the best brake setup for his/her paramotor.

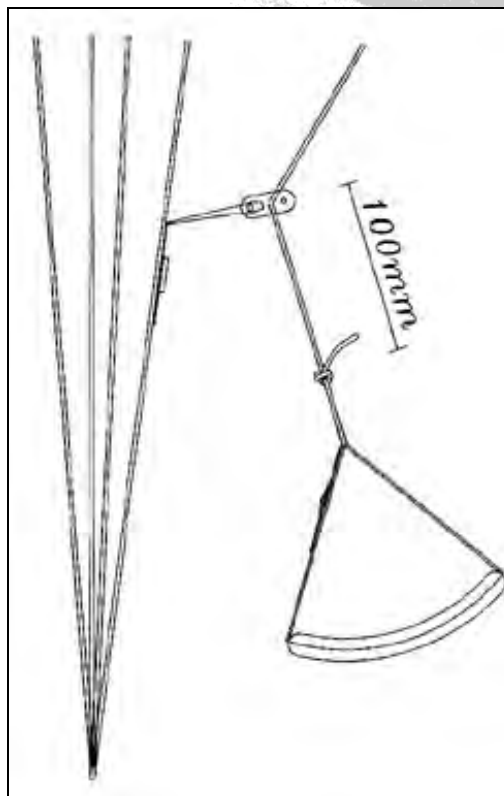

Figure 16-1 Brake Line Adjustment

### 16.3 FIRST CHECK AND PREFLIGHT INSPECTION

With every new glider, the following points should be checked:

- Connection points between the glider and the harness.
- Check that there are no lines twisted, tangled or knotted.
- Check that the risers and speed-system are hooked up to the harness correctly.



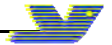

## 16.4 REGULAR INSPECTION CHECKS

- Damage to lines, webbing and thread on the stitching of the harness and risers.
- The stainless steel connection links on the risers are not damaged and are fully closed.
- The pulleys of the speed system are free to move and the lines are not twisted.
- The condition of the brake lines, stainless steel rings and the security of the knot attaching the brake handle to the brake line.
- The sewing, condition of the lines and connection of the lines.
- Damage to hook up points on the glider.
- Internal damage to the ribs and diagonal ribs.
- Damage to the top and bottom panels and seams between panels.

## 16.5 LINE MAINTENANCE

Several groups of suspension lines and one brake line are attached to each riser. The groups are called A, B, C, D and brake lines. The stabilizer lines are connected along with the B-lines. Superaramid lines are known to be sensitive to the influence of the elements. They must be carefully inspected periodically. In his/her own interest, the pilot must observe the following points to ensure maximum performance and safety from the glider.

- Avoid sharp bending and squeezing of lines.
- Take care that people do not step on the lines.
- Do not pull or jerk the lines if they are caught on rocks or vegetation.
- Avoid getting the lines wet. If they do get wet, dry them as soon as possible at room temperature and never store them wet. Never fly with wet lines as their tensile will be temporarily reduced.

**IT IS STRICTLY RECOMMENDED TO CHANGE THE BOTTOM LINES ON EVERY PARAGLIDER ONCE A YEAR OR EVERY 100 HOURS, WHICH EVER COMES FIRST. THE REST OF THE LINES MUST BE CHECKED YEARLY AND REPLACED IF NECESSARY. THIS RECOMMENDATION IS IN LINE WITH ISRAELI REGULATIONS, BINDING IN ISRAEL. AS AN ALTERNATIVE, WE SUGGEST FOR YOU TO FOLLOW THE REGULATIONS SET BY YOUR NATIONAL AUTHORITIES WITH REGARD TO LINE MAINTENANCE AND REPLACEMENT.**

**NEVER REPLACE THE LINES WITH DIFFERENT DIAMETER OR TYPE OF LINES AS ALL GLIDERS WERE LOAD TESTED FOR SAFETY IN THEIR ORIGINAL CONFIGURATION. CHANGING LINE DIAMETER/STRENGTHS CAN HAVE FATAL CONSEQUENCES.**

Every six months one each of lower A, B, C and D line must be tested for minimum 45 % of the rated strength. If the line fails under the load test or does not return to its specified length all the corresponding lines must be replaced (e.g. if the line is rated 100 kg. it must withhold 45 kg. or more)



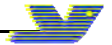

Professional use of gliders: Towing, tandem, schooling and competition flying requires more frequent line inspection and replacement of A, B, C, D and brake lines.

## **17 FREE FLYING**

### **17.1 TAKE OFF**

As this is not a training manual we will not try to teach you launching techniques. We will only briefly go through the different launch techniques to help you get the most out of your glider.

#### **17.1.1 LAYOUT**

Pre-flight check should be done before every flight.

Spread the glider on the ground. Spread the lines, dividing them into eight groups A, B, C, D and brake lines left and right. Make sure the lines are free and not twisted or knotted.

Make sure all the lines are on top of the glider and none are caught on vegetation or rocks under the glider. Lay out the glider in a horseshoe shape. This method insures that all the lines are equally tensioned on launch, and results in an even inflation.

The Flexon rib reinforcements will keep the leading edge open for easy inflation.

The most common reason for a bad launch is a bad layout!

#### **17.1.2 ALPINE LAUNCH OR FORWARD LAUNCH**

The VISTA HP has very good launch behaviour in no wind conditions.

For the best results we recommend the use of the following techniques: Lay out the glider and position yourself in the centre of the wing with the lines almost tight.

With a positive and constant force inflate the wing holding only the A-risers, and smoothly increase your running speed. The wing will quickly inflate and settle above your head without the tendency to stick behind, you may have to pull some brake to stop the wing from overshooting on an aggressive run.

After you leave the A-risers, apply about 15% brakes and the VISTA HP will gently lift you off the ground.

#### **17.1.3 STRONG WIND AND REVERSE LAUNCH**

The VISTA HP has a lot of lifting power and care should be taken in strong wind. It is advisable to have an assistant hold you when attempting a strong wind launch. It also helps if you walk towards the canopy and leave the A-riser just before the glider gets above your head. Then pull a bit of brake to stop the wing from overshooting, but not too much as the glider might pull you off your feet too early. The assistant should let you walk in under the wing on inflation rather than resist the inflation; this reduces the tendency of the glider to lift the pilot prematurely.





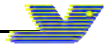

## 17.1.4 TOW OR WINCH LAUNCHING

All APCO gliders are well suited for winching and have no bad tendencies on the winch. With towing it is important to have the wing above your head on launch and not to try and force a stalled wing into the air. This is especially important if the winch operator is using high tension on the winch. Very little brake if any need be applied on launch and during the tow. Directional changes can be made with weight shift rather than brakes. While on tow, the brake pressure will be higher and more force may be needed to make corrections than in normal flight.

For all our gliders we recommend using tow accelerating system. There are different types existing on the market. Please check with your dealer or tow operator for the recommended tow accelerator system. Use of it will eliminate any chance for accidental stalling on tow.

## 17.2 FLIGHT TECHNIQUES

The Vista HP is an easy and pleasant glider to fly, it has excellent performance and was designed for cross country flying, but can be enjoyed by a wide range of pilots too.

### 17.2.1 FLYING SPEED

Indicated trim speed is dependant on the amount of brake the pilot is using, wing loading, altitude above sea level and the accuracy and make of speed probe. The speeds recorded in technical data were at optimum wing loading at sea level using a Flytec 6030 thus there could be a slight variation in speed range numbers that pilots records.

Speed readings in the flight reports could differ as this was measured during testing using various instruments and is an indication of the difference between trim, stall and top speed. The speed range will be the same but the actual numbers may differ.

- With 0% brake the VISTA HP will fly at 39-40 km/h with a sink rate of 1.3m/s.
- At 25% brake the glider will fly at 34-35km/h with minimum sink rate 1.2 m/s.
- The best glide angle is achieved with 0% brakes and 15% speed system.
- With 80% brake the glider will fly at about 25km/h and will be close to the stall point 22km/h.

#### **CAUTION:**

APART FROM WHEN FLARING AT LANDING THERE SHOULD BE NO REASON TO FLY WITH 70% TO 100% BRAKE. THE SINK RATE OF THE GLIDER WILL BE EXCESSIVE AND THERE WILL BE A POSSIBILITY OF ENTERING A DEEP STALL OR FULL STALL SITUATION. THERE IS ALSO THE RISK OF GOING NEGATIVE OR ENTERING A SPIN WHEN ATTEMPTING TO TURN THE GLIDER NEAR THE STALL SPEED.

#### **WARNING:**

The use of the speed system in turbulent conditions or close to the ground is dangerous. While flying with the accelerator, the glider has a reduced angle of attack and is therefore more susceptible to turbulence and may collapse or partially deflate. Gliders react faster when accelerated and may turn more. The accelerator should immediately be released in this case.





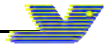

## 17.2.2 THERMAL FLYING

The VISTA HP has good thermalling capacity and will be a pleasure even when you are in a big gaggle or just having fun on a long XC flight.

The glider has high internal pressure and needs very little pilot input even in very turbulent conditions.

In light lift it is advised to make flat turns to keep the glider from banking too much and avoid increasing the sink rate.

In strong lift conditions it is most effective to make small turns in the core with relatively high bank.

For the best climb rate in ridge lift we recommend using about 15% to 20% brake.

## 17.2.3 ASYMMETRIC COLLAPSE

If one side of the glider partially folds or collapses it is important to keep your flying direction by applying weight shift and some brake on the opposite side.

The wing should re-inflate on its own without any input from the pilot.

To help re-inflation it is possible to pull some brake on the collapsed side and release immediately.

In the event of a big deflation, i.e. 70%, it is important to apply brake on the inflated side of the wing, but care must be taken not to pull too much as you could stall the flying side.

The glider is very solid and has a strong tendency to re-inflate after collapse.

## 17.2.4 CRAVAT

In case a cravat should occur from an asymmetric collapse or other manoeuvres, it is important to keep your flying direction by applying some brake on the opposite side and then it can usually be opened by pulling down on the stabilo line of the affected side while countering the turn with the opposite brake and weight shift.

It also helps sometimes to pull Big Ears to release the tension on the affected lines, or a combination of the above techniques, i.e. pulling on the stabilo after pulling Big Ears.

## 17.2.5 FRONT STALL OR SYMMETRIC COLLAPSE

In the event of a front stall the glider will normally re-inflate on its own immediately without any change of direction. To speed up re-inflation briefly apply 30%-40% brake (to pump open the leading edge). **Do not hold the brakes down** permanently to avoid an unwanted stall.

## 17.2.6 B-STALL

The VISTA HP has a very clean, stable B stall.

To enter the B stall the pilot has to pull the first 20-cm slowly until the glider loses forward speed and starts to descend vertically.

Then the pilot can pull more on the B until he/she attains a stable 7 to 9 m/s descent rate.

The Glider has no tendency to front rosette or become pitch unstable. To exit the B stall the pilot releases the B slowly until the glider has regained its shape and then the **last 15 cm fast** to prevent the glider from entering deep stall.

The VISTA HP can be controlled directionally in the B stall by pulling more on one B riser than on the other to create a turn in any direction. The B-stall is a safe controlled way of losing altitude fast without any forward speed.



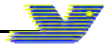

## 17.2.7 BIG EARS

Altitude can be lost in a controlled way by collapsing both tips. To do this, take the outermost A-line (attached on its own riser) on both sides and pull them down until the tips collapse. Pulling one side at a time may be more comfortable and easier, especially for smaller pilots. This should close about 30% of the wing in total. It is possible to steer with weight shift.

To increase the sink rate the pilot can push the speed system after he/she has collapsed the tips. This can give up to about 7 m/s sink-rate with about 40-km/h forward speed. To exit, release the speed system and then release the tip A-lines.

It may sometimes be necessary to apply a little brake to open the tips. If using the brakes to open the tips, it is best to open one tip at a time, this avoids reducing your air-speed.

### **CAUTION:**

DO NOT ATTEMPT ANY EXTREME MANEUUVRES WITH THE TIPS COLLAPSED AS THIS DOUBLES THE LOAD ON THE CENTER LINES AND ATTACHMENT POINTS, WHICH COULD LEAD TO LINE FAILURE.

## 17.2.8 DEEP STALL OR PARACHUTAL STALL

Under normal flying conditions the VISTA HP will have no tendency to enter deep stall. All gliders can however under certain conditions enter and stay in deep stall configuration (as a result of ageing of materials, improper maintenance or pilot induced).

### 17.2.8.1 Signs of parachutal stall

- The pilot has very little or no forward speed and no wind in his face.
- The glider will be fully open but the cells will be bulging in and not out on the bottom surface.
- The glider might have a very slow turning sensation.
- You will have an increased vertical descent.

### 17.2.8.2 Exit from parachutal stall

It is important to recognize this situation. Most accidents involving parachutal stall happen because the pilot did not realize that he was in deep stall.

The best way to exit a parachutal stall is to pull all the A risers down to get the wing flying again. The pilot can pull the riser down until the wing starts to fly again. The moment the wing starts to fly the pilot should release the A risers, or the wing might suffer a frontal collapse.

Alternatively the pilot can push the speed bar to lower the angle of attack and get the wing flying again.

By pulling one or both brakes while in deep stall the pilot can accidentally enter a full stall or spin. (Not recommended)



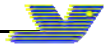

## 17.2.9 SPIRAL DIVES

The VISTA HP has very good behaviour in spiral and has no tendency to stick in the spiral. By progressively applying brake on one side the glider can be put into a spiral dive. Safe high sink rates can be achieved like this. The spiral has to be exited slowly by releasing the brake over one complete turn or the glider may pitch forward and possibly suffer a collapse.

Care must be taken that the pilot has enough height to exit the spiral safely.

Sink rates in excess of 19m/s can be obtained

### **CAUTION:**

SOME GLIDERS CAN BE NEUTRAL IN SPIRAL AND MAY NOT EXIT WITHOUT PILOT INPUT. TO EXIT A NEUTRAL SPIRAL THE PILOT HAS TO LEAN HIS/HER WEIGHT TO THE OUTSIDE OF THE TURN OR APPLY BRAKE ON THE OUTSIDE WING. AS SOON AS THE GLIDER STARTS TO SLOW DOWN IN THE SPIRAL THE OUTSIDE BRAKE MUST BE RELEASED.

PILOTS CAN SUFFER BLACK OUTS IN SPIRALS AND THE PILOT HAS TO EXIT THE SPIRAL AS SOON AS he/she FEELS ANY ABNORMAL SYMPTOMS (Black dots in field of vision or light-headedness).

## 17.2.10 STRONG TURBULENCE

NEVER FLY IN STRONG TURBULENCE!

If you unexpectedly encounter strong turbulence, fly with about 20% brake applied to increase the internal pressure and the angle of attack of the canopy and land as soon as possible. If the air is turbulent on landing approach, land with Big Ears.

Learn to fly actively and to anticipate collapses and prevent them by applying brake when needed before you have unwanted collapses.

## 17.2.11 STEERING NOT FUNCTIONING

If the pilot cannot reach the brake or steering lines for any reason or if they are not functioning properly, (for example: If they break on a damaged point) the pilot can control the glider by pulling down on the rear risers.

Care must be taken when steering like this, as much less input is needed to turn the wing and the response of the wing is also much slower than when using the brakes.

IF YOU PULL TOO MUCH ON ONE OR BOTH RISERS THE GLIDER WILL SPIN OR STALL.

On the landing flare the pilot should be especially careful not to stall the glider too high.



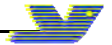

### 17.2.12 LANDING

Before landing, the pilot should determine the wind direction, usually by checking a windsock, flags, smoke or your drift over the ground while doing one or more 360° turns.

- Always land into the wind.
- At a height of about 50 meters your landing setup should begin. The most commonly used one is to head into the wind and depending on the wind strength the pilot should reach his/her landing point by making s-turns.
- At a height of about 15 meters the final part of your descent should be made at trim speed into the wind.
- At a height between half a meter and one meter you can gently flare the glider by pulling gradually down on the brakes to the stall point. When top-landing it is sometimes not necessary to flare or a much smaller flare may be required, especially in strong ridge conditions.

### 17.2.13 TREE LANDING

If it is not possible to land in an open area, steer into the wind towards an unobstructed tree and do a normal landing approach as if the tree is your landing spot. Flare as for a normal landing. On impact hold your legs together and protect your face with your arms.

After any tree landing it is very important to check all the lines, line measurements, and the canopy for damage.

### 17.2.14 WATER LANDING

As you approach landing, release all the buckles (and cross-bracing if present) of the harness except for one leg. Just before landing, release the remaining buckle. It is advisable to enter the water downwind. Let the canopy rotate completely forward until it hits the water with the leading edge openings; the air inside will then be trapped, forming a big air mattress and giving the pilot more time to escape. Less water will enter the canopy this way, making the recovery much easier. **Get away from the glider and lines as soon as possible**, to avoid entanglement. Remember that a ballast bag can be emptied and then inflated with air for a flotation aid.

The canopy should be carefully inspected after a water landing, since it is very easy to cause internal damage to the ribs if the canopy is lifted while containing water. Always lift the canopy by the trailing edge, not by the lines or top or bottom surface fabric.

### 17.2.15 LANDING IN TURBULENCE

One of the safest ways to land a glider in turbulent conditions is to use Big Ears. This reduces the chances of getting a collapse while on final approach. Use weight shift to control your approach. It is possible to keep the ears in until you are ready to flare the glider. Simply release the A-risers and flare the glider, starting a little higher than usual. Practice this in normal conditions before you need it in an emergency.



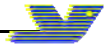

## 18 POWERED FLYING

(This is not a flight teaching manual – just some tips). You must undergo a proper training course.

**NOTE:** Before each start it is necessary to perform a complete check of the paraglider, harness and power unit.

In powered flight most of the wing characteristics remain as described above (chapter 17). Still there is additional information needed, concerning power output, proper matching of the wing/engine/propeller etc. APCO can try to advise for some possible tested combinations, but if you contact your nearest APCO dealer or frame manufacturer they will always be ready to help.

### 18.1 FIRST FLIGHTS

In order to get familiar with your wing we recommend flying with closed trimmers first in stable non-turbulent weather.

Once you feel confident with your wing, you can start experimenting with faster trim settings and speed system, taking all precaution. Learn to use all of the additional speed of the Vista HP – remember, do not exceed the envelope of weather, wing and other parameters to insure safe flying

### 18.2 TAKE-OFF

#### 18.2.1 FORWARD LAUNCH

Please check wind direction, even when it seems that there is no wind at all, there is always some drift.

Therefore be careful in determining the conditions, since in PPG flying it is most important that the launch and initial climb are performed with a head wind (the danger of losing your airspeed while crossing the wind gradient is greatly reduced).

Special attention must be paid to trees, power lines and other obstacles, including the possibility of emerging rotors.

#### Launch preparation

Lay out the paraglider in an arc, downwind of the power unit, with all suspension lines taut and pointing toward center of the power unit. The risers are to be laid on the ground.

Set the trimmers completely closed.

Make sure that you warm up the engine while standing windward of the wing. Stop the engine before clipping in the risers.

#### Now have quick checks if:

- Helmet is on and fastened.
- The risers are clipped into the carabiners.
- The trimmers are properly set.
- Propeller is clear.
- Speed system is functioning, problem free.
- Steering lines and handles are free and not twisted.





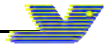

- The engine delivers full power.
- Take off area is clear of obstacles and free to use.

When you are sure all is OK, you can clip in the wing and execute launch as described in paragraph 17.1.2.

From now on you should steer / handle the paraglider facing forward, without looking back over your shoulder. If the wing is retreating and behind you at a low angle, do not turn around as there is a danger of falling on your back and damaging the propeller and catching lines in the propeller, so it should be avoided

During take-off, when you feel the tension on both risers to be equal, make sure the canopy is overhead, open up full power and lean back to counter the engine thrust, so that it can push you forward rather than towards the ground.

The best option is not to use the brakes, allowing the paraglider to rise as it was laid out. If it starts to deviate from its course, pull the opposite riser and run under the centre of the wing while continuing in initial direction.

If the wind suddenly drops, give a stronger pull on the risers.

If the paraglider falls to one side or back too far to be lifted again - kill the engine, cease launch and check the conditions once again.

As the wing rises, the forces grow lighter and it should stabilize above your head without overshooting.

This is the best moment to check if it is inflated well and the lines are not tangled, **but do not stop or turn.**

Once you feel the forces on the risers decrease, run faster and let go of the risers.

See if there is already any opposition on the brakes and, if necessary, use them to correct direction or to increase lift at take-off.

#### **Remember:**

- If the cage of your power unit is not stiff enough, the risers strained during launch can deform it to the extent of collision with the propeller. Before giving it full power, see that the cage does not catch any lines.
- Any brake operation (or steering inputs in general) should be smooth and gentle.





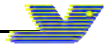

- Do not try to take off until you have your wing overhead. Hitting power before that can cause dangerous oscillations.
- Do not sit in the harness (run) until you are sure you are flying!
- The faster the trim setting is, the more brake input is required to take off.
- The lower the hang points of your power unit are, the easier is the launch.

### 18.2.2 REVERSE LAUNCH (In strong wind)

Reverse launch can be executed holding in one hand both A risers and one brake, with throttle and the second brake in the other hand. With a moderate wind it is by far the best way.

In weaker wind it is better to prepare for forward launch, as running backwards with an engine on your back is not an easy thing to do.

It is reasonable not to pull the wing up until you are really determined to launch, especially when it is clipped in.

Lay down the paraglider with its trailing edge against the wind.

Unfold the wing enough to find the risers and check that no lines are looped over the leading edge.

Stretch the risers against the wind, separating the right and left one.

We suggest that you lay the risers in the same way as you will be turning during reverse launch, and place one riser over the other, with rear risers on top.

It should be done this way because once you clip in, the cage of your power unit will make turning on your own very difficult.

Now run the pre-launch checklist.

After warming up the engine put the power unit on, turn to face the wing, go to the risers and clip them in the appropriate carabiners.

Pull on the front and rear risers to open the cells.

It is a good idea to pull up the wing briefly in order to check that the lines are not tangled.

Holding the risers, brakes and throttle as described above, pull the front risers and raise the canopy over your head.

On most occasions you won't have to use the brakes.

Once you have it overhead, turn around, open the throttle and take off.

#### Remember:

- You are launching with your hands crossed. You have to perfect this technique before trying it with a running engine on your back.
- Any brake operation (or steering inputs in general) should be smooth and gentle.
- Do not try to take off until you have your wing overhead, hitting the throttle early can cause dangerous oscillations.



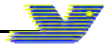

- Do not sit in the harness until you are sure you are flying!
- The faster the trim setting is, the more brake input is required to take off.
- When clipping in the crossed risers, you can find proper connection of the speed system particularly hard. Be careful not to confuse the risers!

### 18.2.3 CLIMBING

Once you are safely airborne, continue heading against the wind, using brakes to correct the direction.

#### **Do not try to climb too steeply.**

In powered flight the Vista HP behaves more like an airplane than a paraglider, and it is good idea to regard it as such. If there are no obstacles present, it is by far safer to fly level for a while after take-off, clearing the ground gradually, gaining some speed before converting it to height with a brief pull on the brakes.

Another reason not to try climbing too steeply is the risk connected with engine failure at low altitude.

Vista HP in a steep climb does not stay behind as much as conventional paragliders.

The SRS prevents or delays possible stall, but low speed at low altitude carries inherent danger of stall which even SRS will not be able to fully prevent

Besides, you should always be able to land safely in case of engine malfunction, so it's better not to take unnecessary chances and always fly with a safe margin of speed and height

Depending on the power unit geometry, it is possible that after take-off you will notice a propeller torque (known as P-factor).

It will try to turn you around, so counter-steer with a brake, trimmer set or harness cross-bracing.

When climbing steeply with slow trim settings and high power output beware of the possibility of stall.

Due to considerable vertical distance between thrust axis and wing chord - the range of safe power operation is closely connected to your skills and equipment.

Power-unit induced oscillations Certain configurations of engine weight, output and propeller diameter can cause oscillations, during which the pilot is being lifted to one side by the torque effect, swings down due to his weight, then is lifted again and so on.

#### **To avoid this you can:**

- Change the throttle setting.
- Adjust the cross bracing to counteract the torque (if there is one present).
- Shift yourself to the other side of the harness and/or change the trimmer setting.

The best method is to fasten opposite cross-bracing, or apply some weight-shift.

Such oscillations usually occur at full power - the greater the engine output and propeller diameter, the bigger the swings.

In addition there are often too late or wrong pilot reactions, increasing the problem instead of solving it.

In this case the safest way to deal with this question is to close the throttle and release the brakes.



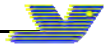

Especially less-experienced pilots tend to overreact.

This is called a pilot-induced oscillation, and proven solution is to **leave the brakes alone**.

### 18.3 LEVEL FLIGHT

If you have a variometer or altimeter – check it regularly.

In level flight it is very easy to start climbing unintentionally.

The instruments will help you optimize speed and fuel economy.

Of course each flight depends on configuration of your gear, but due to Vista HP's ability to fly safely without constant piloting, it will let you adjust everything to the best effect.

Good knowledge of weather conditions (e.g. wind at different altitudes) and knowledgeable use of thermals, convergence or other kinds of lift will help you greatly reduce fuel consumption and increase flight range.

Of course the engine is always there to bring you in the right place.

Do not hesitate to thermal with the Vista HP in order to win some altitude and spare fuel - you will be surprised how efficient it is.

Closing the trimmers will make the climb ratio even better.

### 18.4 TRIMMERS AND SPEED-SYSTEM SETTINGS

You are free to experiment with all possible settings, **as long as you are on safe altitude and watch the weather**. Fully opened trimmers increase the speed of the wing and with it overall penetration, but carry inherent, increased risk of collapse and require caution and prudence.

As forces on the brakes grow at high speeds, the weight shifting or steering with STABILO STEERING system becomes increasingly effective.

**STABILO STEERING system can be used in all trimmer and speed system settings, also in combination with main brake handles.** At maximum speed bar and fully opened trimmers we recommend to prefer steering with STABILO STEERING system.

Turns executed in this way will be slightly wider, but strength needed to initiate the turn will be smaller and there will be no decrease in speed.

On the other hand, slow trimmer settings decreases sink and steering forces, so it is possible to efficiently use the thermals.

Worth noting is the Vista HP impressive speed range -the maximum speed is almost three times greater than stall speed.

Turns can be much improved by additional use of throttle, speed-system etc. Once you master these techniques, you will be able to execute fully coordinated and effective turns.

#### REMEMBER:

Trimmer setting is another part of the pre-start check list!

If it will be asymmetric, the wing will be turning all the time.





## 18.5 LANDING

in PPG flying there are two kinds of landing: with and without power.

### 18.5.1 POWER OFF LANDING

At an altitude of 50 meters switch the engine off and glide as you would on a conventional paraglider.

It reduces the chances of damaging the propeller on landing, but on the other hand there is only one attempt possible -so it has to be done right!

Vista HP preserves the energy well, so there is a long float necessary, exchanging the abundant speed for lift with your brakes.

### 18.5.2 POWERED LANDING

Make a flat approach with the engine idling, then level out and lose the speed before final flare.

**Immediately on landing, switch off the engine.**

The main advantage of this procedure is of course the possibility of going around with the wing again (repeating the approach) if anything goes wrong.

Still, if you forget to switch off the ignition before the wing falls down, there is a considerable risk of damaging propeller, catching lines in it or even suffering injuries connected with falling on your running engine.

#### **Remember:**

- Whenever possible, get to know the landing field before taking off.
- Check the wind direction before planning the approach.
- Landing with power off requires much less space.
- In case of any doubt, practice the landing until you feel totally safe
- Never place the power unit downwind of the paraglider.
- Check, double check and then check once again that there is no fuel leakage.
- Do you have enough fuel for the flight? It is always better to have too much than too little!
- Check that there is nothing loose in the harness that could possibly contact the propeller in flight.
- Whenever you encounter a problem, fix it AT ONCE however small it is!
- Always put on and lock helmet before getting in the harness.
- Before each launch run a full pre-flight inspection.
- After landing, continue to maintain the wing's direction straight, as on turning you always risk getting lines in the propeller.
- Turn only if there is danger.





- Do not fly over water, between trees or power lines and other places where engine failure will leave you helpless, always make sure you have possibility for emergency landing.
- Mind the turbulence caused by other gliders or even by yourself, especially when flying low.
- It is not reasonable to let go of the brakes below 100 meters, because a possible power unit malfunction may require immediate attention.
- In general never trust your engine, as it can stop at any moment. Always fly prepared for engine failure.
- Unless it is absolutely necessary (e.g. collision avoidance), do not execute tight turns against the torque direction.  
Especially when climbing you can easily enter a stall or negative spin.
- Do not fly with tail wind at low altitudes,- it narrows your options !
- Do not wait for the problem to grow - any change of engine sound or a vibration may indicate a problem. You'll never know until you land and check it out!
- Be certain of your navigation
- Remember that not everyone is fond of your engine noise.

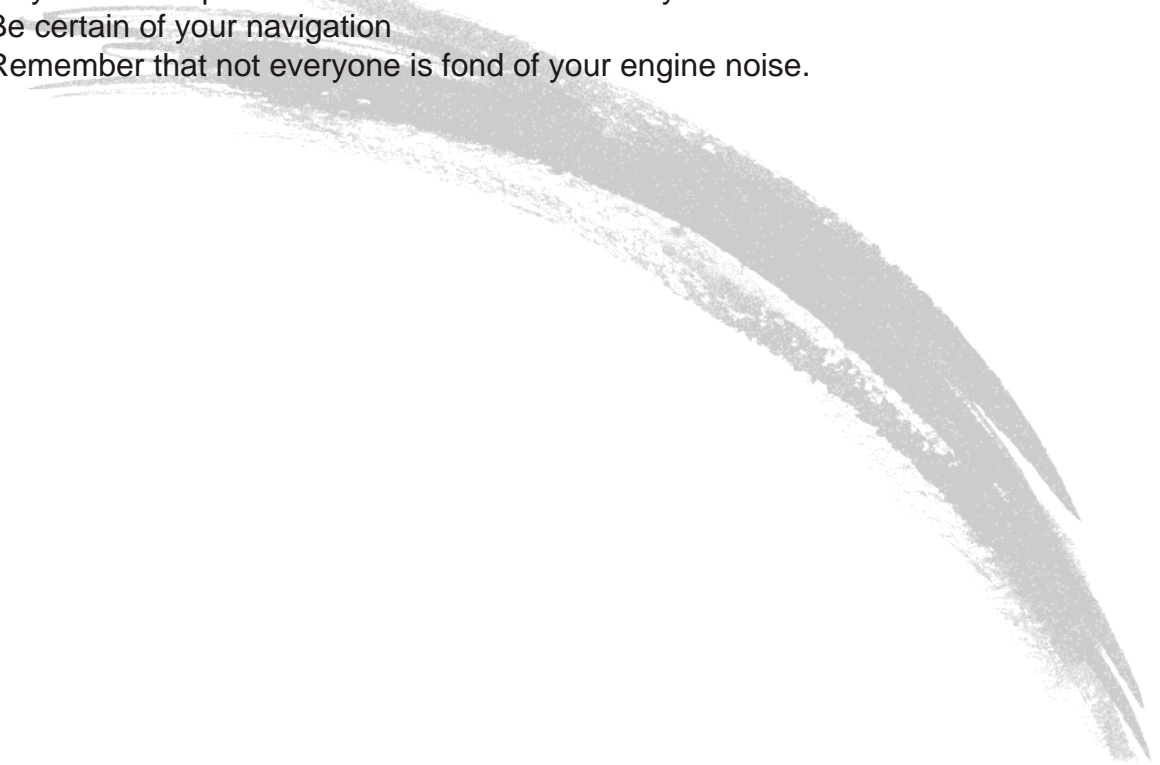





## 19 PACKING

Spread the canopy completely out on the ground. Separate the lines to the left and the right side of the glider. If the risers are removed from the harness, join the two risers together by passing one carabiner loop through the other. This keeps them neatly together and helps to stop line tangles.

Fold the canopy alternately from the right and left sides, working towards the centre, press out the air, working from the rear towards the front. Place the risers at the trailing edge of the folded canopy and use them to finally roll up the canopy.

## 20 MAINTENANCE & CLEANING

Cleaning should be carried out with water and if necessary, gentle soap. If the glider comes in contact with salt water, clean thoroughly with fresh water. **Do not use solvents of any kind**, as this may remove the protective coatings and destroy the fabric.

### 20.1 BUTT HOLES (Velcro closure on trailing edge tip)

In order to empty sand and small stones from the glider simply shake the sand or small stones into the wing tip and open the **Butt holes (Velcro closure on trailing edge tip)** to empty. Do not forget to close the **Butt holes** afterwards.



## 21 STORAGE

When the glider is not in use, the glider should be stored in a cool, dry place. A wet glider should first be dried (out of direct sunlight). Protect the glider against sunlight (UV radiation). When on the hill keep the glider covered or in the bag. Never store or transport the glider near paint, petrol or any other chemicals.







**Do not leave your paraglider in the trunk of a car or exposed to the sun.**

Temperatures on a hot summer's day in a closed environment: car, etc. can easily reach over 60°C

At these temperatures Nylon permanently changes its characteristics which may alter the behavior and shape of the wing.

It will cause permanent damage to the paraglider, rendering it non-airworthy. APCO's warranty will not be applicable.

## **22 DAMAGE**

Using spinnaker repair tape (for non-siliconized cloth) can repair tears in the sail (up to 5cm). A professional repairer should repair greater damage.

## **23 GENERAL ADVICE**

A qualified person or agent of the company should check the glider every year.

The glider is carefully manufactured and checked by the factory. Never make changes to the canopy or the lines. Changes can introduce dangerous flying characteristics and will not improve flying performance.

Do not put the glider in direct sunlight when not necessary. In order to protect the glider during transportation or waiting time we recommend one of our lightweight storage bags.

If you have any doubts about flying conditions - do not begin.

If you have any questions, please contact your dealer or us.

Lastly, be equipped with a certified emergency parachute and helmet on every flight.





# 24 VISTA HP SMALL SKETCHES

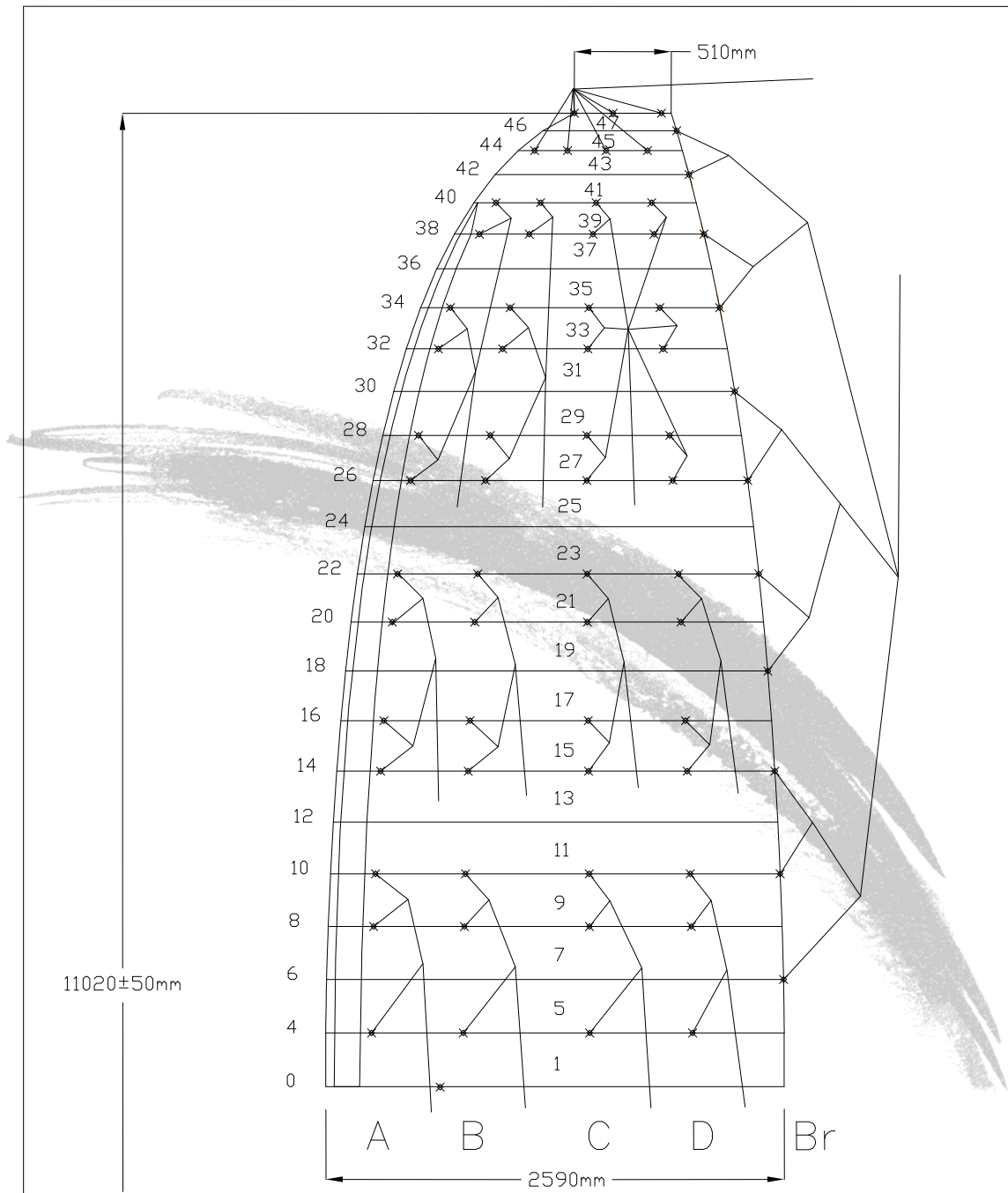

\* All measurements are in mm

Drawn by Adam Wechsler	Part N	Toll ±10	
Date 21.05.2009	Name	Drawing N	
Scale	Lines sketch		VH.15.10.38
Approved Anatoly Cohn	Product		Revision
APCO Aviation LTD.	Vista HP <S>		E



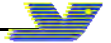

# 25 VISTA HP MEDIUM SKETCHES

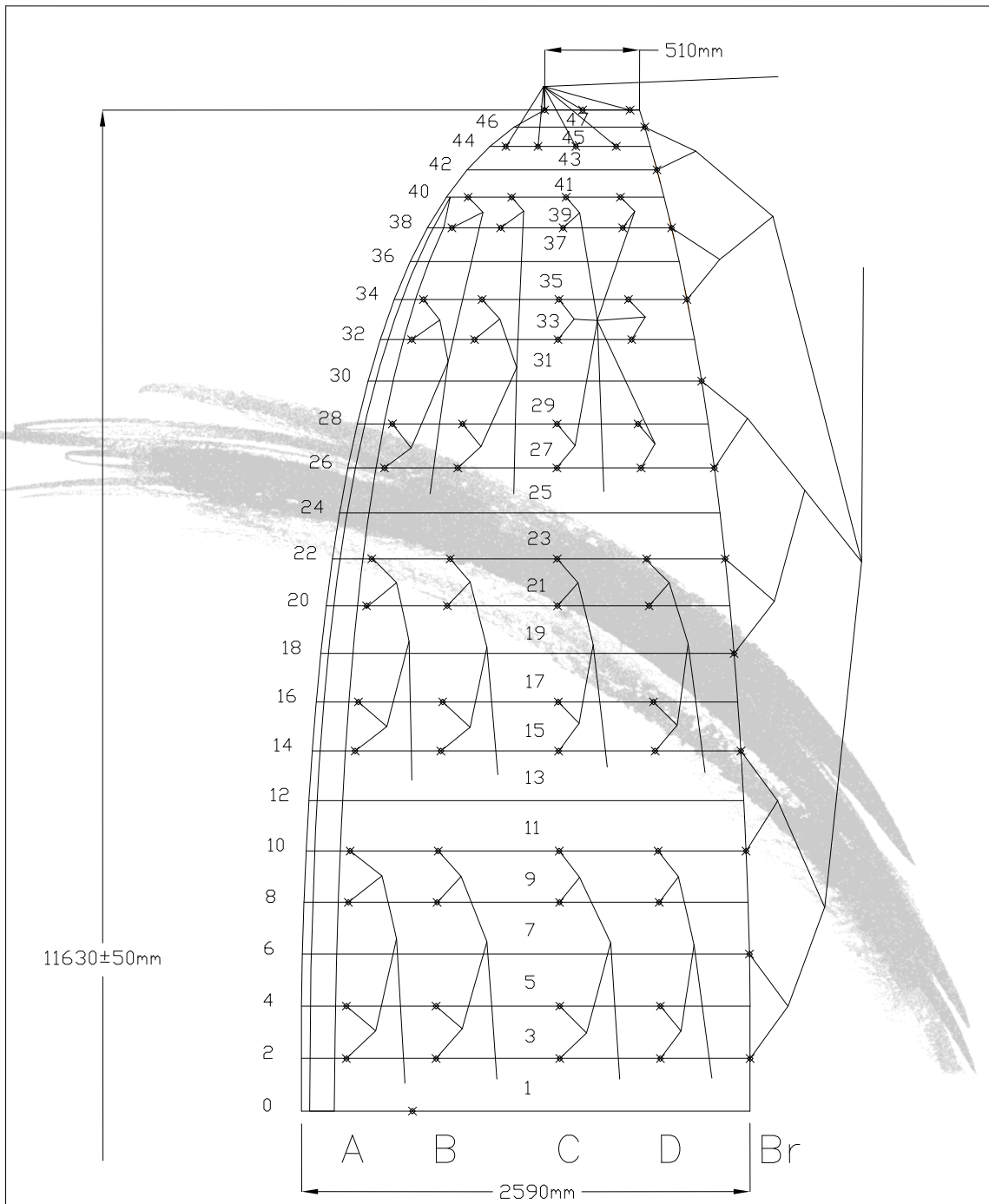

\* All measurements are in mm

Drawn by Adam Wechsler	Part N	Toll ±10	
Date 21.05.2009	Name	Drawing N	
Scale	Lines sketch	VH.15.10.38	
Approved Anatoly Cohn	Product	Revision	
APCO Aviation LTD.	Vista HP <M>	E	





# 26 VISTA HP SMALL CERTIFICATION

para-test.com



paragliding by air turquoise

Air Turquoise SA  
Rte du Pré-au-Comte 8 | CH-1844 Villeneuve  
tel. +41 21 965 65 65 | mobile +41 79 202 52 30  
info@para-test.com

## Flight test report



Manufacturer	<b>Apco Aviation Ltd.</b>	Certification number	PG_0237.2009
Address	7, Chalamish St., Industrial park 38900 Caesarea Israel	Date of flight test	06. 05. 2009
Representative	None	Place of test	Villeneuve
Glider model	<b>Vista HP S</b>	<b>Classification</b>	<b>B</b>
Trimmer	yes: closed		

	<b>Test pilot</b>	Fukuoka Seiko	Zoller Alain
	<b>Harness</b>	Sup'Air - Access	Sup'Air - Altiplume L
	<b>Total weight in flight (kg)</b>	70	100
<b>1. Inflation/Take-off</b>	<b>A</b>		
Rising behaviour	Smooth, easy and constant rising	A	Smooth, easy and constant rising
Special take off technique required	No	A	No
<b>2. Landing</b>	<b>A</b>		
Special landing technique required	No	A	No
<b>3. Speed in straight flight</b>	<b>B</b>		
Trim speed more than 30 km/h	Yes	A	Yes
Speed range using the controls larger than 10 km/h	Yes	A	Yes
Minimum speed	Less than 25 km/h	A	25 km/h to 30 km/h
<b>4. Control movement</b>	<b>A</b>		
Max. weight in flight up to 80 kg			
Symmetric control pressure / travel	Increasing / greater than 55 cm	A	not available
Max. weight in flight 80 kg to 100 kg			
Symmetric control pressure / travel	not available	0	Increasing / greater than 60 cm
Max. weight in flight greater than 100 kg			
Symmetric control pressure / travel	not available	0	not available
<b>5. Pitch stability exiting accelerated flight</b>	<b>A</b>		
Dive forward angle on exit	Dive forward less than 30°	A	not available
Collapse occurs	No	A	not available
<b>6. Pitch stability operating controls during accelerated flight</b>	<b>A</b>		
Collapse occurs	No	A	not available
<b>7. Roll stability and damping</b>	<b>A</b>		
Oscillations	Reducing	A	Reducing
<b>8. Stability in gentle spirals</b>	<b>A</b>		
Tendency to return to straight flight	Spontaneous exit	A	Spontaneous exit
<b>9. Behaviour in a steeply banked turn</b>	<b>B</b>		
Sink rate after two turns	More than 14 m/s	B	More than 14 m/s
<b>10. Symmetric front collapse</b>	<b>A</b>		
Entry	Rocking back less than 45°	A	Rocking back less than 45°
Recovery	Spontaneous in less than 3 s	A	Spontaneous in less than 3 s
Dive forward angle on exit / Change of course	Dive forward 0° to 30° / Keeping course	A	Dive forward 0° to 30° / Keeping course
Cascade occurs	No	A	No
With accelerator			
Entry	Rocking back less than 45°	A	not available
Recovery	Spontaneous in less than 3 s	A	not available





Dive forward angle on exit / Change of course	Dive forward 0° to 30° / Entering a turn of less than 90°	A	not available	0
Cascade occurs	No	A	not available	0
<b>11. Exiting deep stall (parachutal stall)</b>	<b>A</b>			
Deep stall achieved	Yes	A	Yes	A
Recovery	Spontaneous in less than 3 s	A	Spontaneous in less than 3 s	A
Dive forward angle on exit	Dive forward 0° to 30°	A	Dive forward 0° to 30°	A
Change of course	Changing course less than 45°	A	Changing course less than 45°	A
Cascade occurs	No	A	No	A
<b>12. High angle of attack recovery</b>	<b>A</b>			
Recovery	Spontaneous in less than 3 s	A	Spontaneous in less than 3 s	A
Cascade occurs	No	A	No	A
<b>13. Recovery from a developed full stall</b>	<b>B</b>			
Dive forward angle on exit	Dive forward 0° to 30°	A	Dive forward 30° to 60°	B
Collapse	No collapse	A	No collapse	A
Cascade occurs (other than collapses)	No	A	No	A
Rocking back	Less than 45°	A	Less than 45°	A
Line tension	Most lines tight	A	Most lines tight	A
<b>14. Asymmetric collapse</b>	<b>B</b>			
<i>With 50% collapse</i>				
Change of course until re-inflation / Maximum dive forward or roll angle	Less than 90° / Dive or roll angle 0° to 15°	A	Less than 90° / Dive or roll angle 0° to 15°	A
Re-inflation behaviour	Spontaneous re-inflation	A	Spontaneous re-inflation	A
Total change of course	Less than 360°	A	Less than 360°	A
Collapse on the opposite side occurs	No	A	No	A
Twist occurs	No	A	No	A
Cascade occurs	No	A	No	A
<i>With 75% collapse</i>				
Change of course until re-inflation / Maximum dive forward or roll angle	Less than 90° / Dive or roll angle 0° to 15°	A	90° to 180° / Dive or roll angle 15° to 45°	B
Re-inflation behaviour	Spontaneous re-inflation	A	Spontaneous re-inflation	A
Total change of course	Less than 360°	A	Less than 360°	A
Collapse on the opposite side occurs	No	A	No	A
Twist occurs	No	A	No	A
Cascade occurs	No	A	No	A
<i>With 50% collapse and accelerator</i>				
Change of course until re-inflation / Maximum dive forward or roll angle	Less than 90° / Dive or roll angle 0° to 15°	A	not available	0
Re-inflation behaviour	Spontaneous re-inflation	A	not available	0
Total change of course	Less than 360°	A	not available	0
Collapse on the opposite side occurs	No	A	not available	0
Twist occurs	No	A	not available	0
Cascade occurs	No	A	not available	0
<i>With 75% collapse and accelerator</i>				
Change of course until re-inflation / Maximum dive forward or roll angle	Less than 90° / Dive or roll angle 15° to 45°	A	not available	0
Re-inflation behaviour	Spontaneous re-inflation	A	not available	0
Total change of course	Less than 360°	A	not available	0
Collapse on the opposite side occurs	No	A	not available	0
Twist occurs	No	A	not available	0
Cascade occurs	No	A	not available	0
<b>15. Directional control with a maintained asymmetric collapse</b>	<b>A</b>			
Able to keep course	Yes	A	Yes	A
180° turn away from the collapsed side possible in 10 s	Yes	A	Yes	A
Amount of control range between turn and stall or spin	More than 50 % of the symmetric control travel	A	More than 50 % of the symmetric control travel	A
<b>16. Trim speed spin tendency</b>	<b>A</b>			
Spin occurs	No	A	No	A







<b>17. Low speed spin tendency</b>	<b>A</b>			
Spin occurs	No	A	No	A
<b>18. Recovery from a developed spin</b>	<b>A</b>			
Spin rotation angle after release	Stops spinning in less than 90°	A	Stops spinning in less than 90°	A
Cascade occurs	No	A	No	A
<b>19. B-line stall</b>	<b>A</b>			
Change of course before release	Changing course less than 45°	A	Changing course less than 45°	A
Behaviour before release	Remains stable with straight span	A	Remains stable with straight span	A
Recovery	Spontaneous in less than 3 s	A	Spontaneous in less than 3 s	A
Dive forward angle on exit	Dive forward 0° to 30°	A	Dive forward 0° to 30°	A
Cascade occurs	No	A	No	A
<b>20. Big ears</b>	<b>A</b>			
Entry procedure	Dedicated controls	A	Dedicated controls	A
Behaviour during big ears	Stable flight	A	Stable flight	A
Recovery	Spontaneous in less than 3 s	A	Spontaneous in less than 3 s	A
Dive forward angle on exit	Dive forward 0° to 30°	A	Dive forward 0° to 30°	A
<b>21. Big ears in accelerated flight</b>	<b>A</b>			
Entry procedure	Dedicated controls	A	not available	0
Behaviour during big ears	Stable flight	A	not available	0
Recovery	Spontaneous in less than 3 s	A	not available	0
Dive forward angle on exit	Dive forward 0° to 30°	A	not available	0
Behaviour immediately after releasing the accelerator while maintaining big ears	Stable flight	A	not available	0
<b>22. Behaviour exiting a steep spiral</b>	<b>A</b>			
Tendency to return to straight flight	Spontaneous exit	A	Spontaneous exit	A
Turn angle to recover normal flight	Less than 720°, spontaneous recovery	A	Less than 720°, spontaneous recovery	A
Sink rate when evaluating spiral stability [m/s]	19		22	
<b>23. Alternative means of directional control</b>	<b>A</b>			
180° turn achievable in 20 s	Yes	A	Yes	A
Stall or spin occurs	No	A	No	A
<b>24. Any other flight procedure and/or configuration described in the user's manual</b>	<b>A</b>			
Procedure works as described	Yes	A	Yes	A
Procedure suitable for novice pilots	Yes	A	Yes	A
Cascade occurs	No	A	No	A
<b>25. Comments of test pilot</b>				
Comments	The glider can stay in neutral spiral if more than 14 m/s			





# 27 VISTA HP MEDIUM CERTIFICATION

para-test.com



paragliding by air turquoise

Air Turquoise SA  
Rte du Pré-au-Comte 8 | CH-1844 Villeneuve  
tel. +41 21 965 65 65 | mobile +41 79 202 52 30  
info@para-test.com

## Flight test report



Manufacturer	<b>Apco Aviation Ltd.</b>	Certification number	PG_0236.2009
Address	7, Chalamish St., Industrial park 38900 Caesarea Israel	Date of flight test	23. 03. 2009
Representative	None	Place of test	Villeneuve
Glider model	<b>Vista HP M</b>	<b>Classification</b>	<b>C</b>
Trimmer	yes: closed		

	<b>Test pilot</b>	Thurnheer Claude	Zoller Alain
	<b>Harness</b>	Sup Air - Evo XC2 M	Gin Gliders - Gingo 2 L
	<b>Total weight in flight (kg)</b>	85	120
<b>1. Inflation/Take-off</b>	<b>A</b>		
Rising behaviour	Smooth, easy and constant rising	A	Smooth, easy and constant rising
Special take off technique required	No	A	No
<b>2. Landing</b>	<b>A</b>		
Special landing technique required	No	A	No
<b>3. Speed in straight flight</b>	<b>A</b>		
Trim speed more than 30 km/h	Yes	A	Yes
Speed range using the controls larger than 10 km/h	Yes	A	Yes
Minimum speed	Less than 25 km/h	A	Less than 25 km/h
<b>4. Control movement</b>	<b>C</b>		
Max. weight in flight up to 80 kg			
Symmetric control pressure / travel	not available	0	not available
Max. weight in flight 80 kg to 100 kg			
Symmetric control pressure / travel	Increasing / greater than 60 cm	A	not available
Max. weight in flight greater than 100 kg			
Symmetric control pressure / travel	not available	0	Increasing / 50 cm to 65 cm
<b>5. Pitch stability exiting accelerated flight</b>	<b>0</b>		
Dive forward angle on exit	not available	0	not available
Collapse occurs	not available	0	not available
<b>6. Pitch stability operating controls during accelerated flight</b>	<b>0</b>		
Collapse occurs	not available	0	not available
<b>7. Roll stability and damping</b>	<b>A</b>		
Oscillations	Reducing	A	Reducing
<b>8. Stability in gentle spirals</b>	<b>A</b>		
Tendency to return to straight flight	Spontaneous exit	A	Spontaneous exit
<b>9. Behaviour in a steeply banked turn</b>	<b>B</b>		
Sink rate after two turns	More than 14 m/s	B	More than 14 m/s
<b>10. Symmetric front collapse</b>	<b>A</b>		
Entry	Rocking back less than 45°	A	Rocking back less than 45°
Recovery	Spontaneous in less than 3 s	A	Spontaneous in less than 3 s
Dive forward angle on exit / Change of course	Dive forward 0° to 30° / Keeping course	A	Dive forward 0° to 30° / Keeping course
Cascade occurs	No	A	No
With accelerator			
Entry	not available	0	not available
Recovery	not available	0	not available





Dive forward angle on exit / Change of course	not available	0	not available	0
Cascade occurs	not available	0	not available	0
<b>11. Exiting deep stall (parachutal stall)</b>	<b>A</b>			
Deep stall achieved	Yes	A	Yes	A
Recovery	Spontaneous in less than 3 s	A	Spontaneous in less than 3 s	A
Dive forward angle on exit	Dive forward 0° to 30°	A	Dive forward 0° to 30°	A
Change of course	Changing course less than 45°	A	Changing course less than 45°	A
Cascade occurs	No	A	No	A
<b>12. High angle of attack recovery</b>	<b>A</b>			
Recovery	Spontaneous in less than 3 s	A	Spontaneous in less than 3 s	A
Cascade occurs	No	A	No	A
<b>13. Recovery from a developed full stall</b>	<b>B</b>			
Dive forward angle on exit	Dive forward 0° to 30°	A	Dive forward 30° to 60°	B
Collapse	No collapse	A	not available	0
Cascade occurs (other than collapses)	No	A	No	A
Rocking back	Less than 45°	A	Less than 45°	A
Line tension	Most lines tight	A	Most lines tight	A
<b>14. Asymmetric collapse</b>	<b>B</b>			
<i>With 50% collapse</i>				
Change of course until re-inflation / Maximum dive forward or roll angle	Less than 90° / Dive or roll angle 15° to 45°	A	Less than 90° / Dive or roll angle 15° to 45°	A
Re-inflation behaviour	Spontaneous re-inflation	A	Spontaneous re-inflation	A
Total change of course	Less than 360°	A	Less than 360°	A
Collapse on the opposite side occurs	No	A	No	A
Twist occurs	No	A	No	A
Cascade occurs	No	A	not available	0
<i>With 75% collapse</i>				
Change of course until re-inflation / Maximum dive forward or roll angle	90° to 180° / Dive or roll angle 15° to 45°	B	90° to 180° / Dive or roll angle 15° to 45°	B
Re-inflation behaviour	Spontaneous re-inflation	A	Spontaneous re-inflation	A
Total change of course	Less than 360°	A	Less than 360°	A
Collapse on the opposite side occurs	No	A	No	A
Twist occurs	No	A	No	A
Cascade occurs	No	A	No	A
<i>With 50% collapse and accelerator</i>				
Change of course until re-inflation / Maximum dive forward or roll angle	not available	0	not available	0
Re-inflation behaviour	not available	0	not available	0
Total change of course	not available	0	not available	0
Collapse on the opposite side occurs	not available	0	not available	0
Twist occurs	not available	0	not available	0
Cascade occurs	not available	0	not available	0
<i>With 75% collapse and accelerator</i>				
Change of course until re-inflation / Maximum dive forward or roll angle	not available	0	not available	0
Re-inflation behaviour	not available	0	not available	0
Total change of course	not available	0	not available	0
Collapse on the opposite side occurs	not available	0	not available	0
Twist occurs	not available	0	not available	0
Cascade occurs	not available	0	not available	0
<b>15. Directional control with a maintained asymmetric collapse</b>	<b>A</b>			
Able to keep course	Yes	A	Yes	A
180° turn away from the collapsed side possible in 10 s	Yes	A	Yes	A
Amount of control range between turn and stall or spin	More than 50 % of the symmetric control travel	A	not available	0
<b>16. Trim speed spin tendency</b>	<b>A</b>			
Spin occurs	No	A	No	A





<b>17. Low speed spin tendency</b>	<b>A</b>			
Spin occurs	No	A	No	A
<b>18. Recovery from a developed spin</b>	<b>A</b>			
Spin rotation angle after release	Stops spinning in less than 90°	A	Stops spinning in less than 90°	A
Cascade occurs	No	A	No	A
<b>19. B-line stall</b>	<b>A</b>			
Change of course before release	Changing course less than 45°	A	Changing course less than 45°	A
Behaviour before release	Remains stable with straight span	A	Remains stable with straight span	A
Recovery	Spontaneous in less than 3 s	A	Spontaneous in less than 3 s	A
Dive forward angle on exit	Dive forward 0° to 30°	A	Dive forward 0° to 30°	A
Cascade occurs	No	A	No	A
<b>20. Big ears</b>	<b>A</b>			
Entry procedure	Dedicated controls	A	Dedicated controls	A
Behaviour during big ears	Stable flight	A	Stable flight	A
Recovery	Spontaneous in less than 3 s	A	Spontaneous in less than 3 s	A
Dive forward angle on exit	Dive forward 0° to 30°	A	Dive forward 0° to 30°	A
<b>21. Big ears in accelerated flight</b>	<b>0</b>			
Entry procedure	not available	0	not available	0
Behaviour during big ears	not available	0	not available	0
Recovery	not available	0	not available	0
Dive forward angle on exit	not available	0	not available	0
Behaviour immediately after releasing the accelerator while maintaining big ears	not available	0	not available	0
<b>22. Behaviour exiting a steep spiral</b>	<b>A</b>			
Tendency to return to straight flight	Spontaneous exit	A	Spontaneous exit	A
Turn angle to recover normal flight	Less than 720°, spontaneous recovery	A	Less than 720°, spontaneous recovery	A
Sink rate when evaluating spiral stability [m/s]	16		22	
<b>23. Alternative means of directional control</b>	<b>A</b>			
180° turn achievable in 20 s	Yes	A	Yes	A
Stall or spin occurs	No	A	No	A
<b>24. Any other flight procedure and/or configuration described in the user's manual</b>	<b>A</b>			
Procedure works as described	Yes	A	Yes	A
Procedure suitable for novice pilots	Yes	A	Yes	A
Cascade occurs	No	A	No	A
<b>25. Comments of test pilot</b>				
Comments				



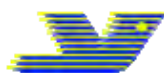

APCO wishes you many hours of enjoyable flying.

Take Air!

